



With gentle non-marking tracks, the ML810 is just as at home indoors as outdoors!



The heavy-duty construction of the ML810 and its true all-terrain capability makes it the ideal machine for rough and tough sites.



At only 1.2m wide and only 1.98m high, doorway access is easily achieved.



Weighing in at only 2.2 tonnes, the ML810 is very easily transported behind most tradesman's vehicles. A typical trailer package grosses at around 2.75 tonnes.

SPECIFICATIONS

Max working height	8.10 m
Max platform height	6.10 m
Max horizontal working outreach	3.00 m
Lift capacity / SWL	200 kg
Basket rotation	2 x 110°
A Platform width	0.90 m
B Platform length	0.80 m
C Length - stowed	2.47 m
D Trackbase	1.20 m
E Width	1.20 m
F Height - stowed	1.98 m
Turning radius	zero
Gradeability	30%
Maximum tilt value	5°
Drive speed - stowed	1.8 km/h
Drive speed - raised	0.8 km/h
Weight	2200 kg
Max. ground bearing pressure	50 kN/m ²

Complies with AS1418.10

(E & OE.)

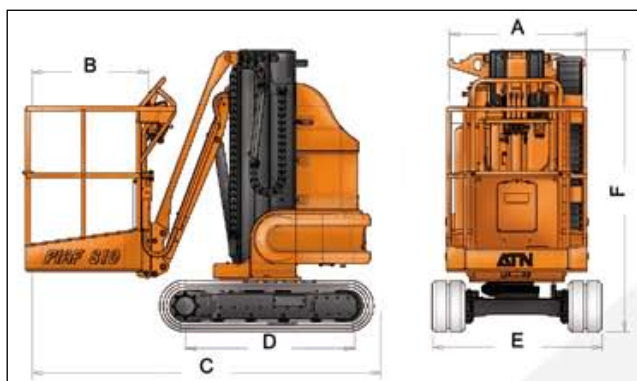

ADVANTAGES

- Efficiency thanks to the 2 x 110° rotation of the top.
- Designed for any indoor or outdoor job site.
- Smooth operating thanks to the hydraulic joystick.
- Easy to operate.
- Zero turning radius.
- Preserving fragile floors.
- Designed and manufactured for heavy-duty use.

STANDARD FEATURES

- Non-marking rubber tracks.
- Progressive hydraulic joystick transmission.
- Driving operated by a hydraulic joystick.
- 575 Ah centralized battery filling system.
- 85 A battery charger.
- 2 drive speeds.
- Lifting facilities.
- Emergency hand-pump.
- Battery indicator with 80% discharge cut-off.
- Tilt indicator with buzzer.
- Overload sensor.
- System preventing from tipping over.
- Hour meter.
- Strong large size platform.
- Automatic 5° power cut out.

OPTIONS

- Air line to platform.
- 220V AC power to platform.
- Special paint colour(s).

